

A GENERALIZED FORMULATION AND ANALYSIS OF SHUNT
FAULTS IN MULTI-PHASE TRANSMISSION SYSTEMS

صياغة وتحليل أخطاء التوازي في نظم النقل متعددة الأوجه

BY

I. I. I. Mansy

Associate Prof., Member IEEE

University of El-Mansoura, Faculty of Engineering,
Electrical Power & Machines Dept., El-Mansoura, Egypt

الخلاصة: هذا البحث يقوم بتطبيق الأسلوب التقني للنظام ثلاثي الأوجه لمعالجة أخطاء التوازي في النظم متعددة الأوجه .

وقد طور هذا العمل معادلتين لتحديد التيارات والجهود أثناء الخطأ لكن أنواع الخطأ .
وكذلك تم استخراج المعادلات للتيارات والجهود بحيث يمكن تطبيقها لأي ترتيب وجبي وكذلك لأي نوع من أنواع الخطأ. ويقدم هذا البحث توضيحاً لصحة المعادلات المستنتجة عن طريق الحسابات المتوقعة والموضحة في هذا العمل وذلك لاستنتاج معلومات هامة لإداء نظم النقل متعددة الأوجه.

ABSTRACT

This paper is devoted to the extension of the existing three phase technique for a generalized treatment of shunt faults in multi-phase systems. The expressions derived in this paper for fault currents and voltages are applicable to any phase order, fault type and combination of faults and can account for the fault impedance/admittance. Several illustrative calculations are presented to demonstrate the validity of expressions derived and to derive important informations regarding performance of multi-phase transmission systems.

INTRODUCTION

Multi-phase transmission employing more than three phase has been investigated for the last several years as a potential alternative to the conventional three phase system [1]. In the process, the attention has been focussed mainly on six-phase and twelve-phase systems. Fault analysis is one of the most important aspects of transmission planning and design activity. A number of publications dealing with this aspect have appeared in the literature [2-11] and the efforts to sort out the various complexities associated with the fault analysis of multi-phase system is continually growing.

The fault analysis of six-phase system was carried out by several authors employing symmetrical components transformations [2-5], Clarke's component transformation [5], $\alpha-\beta-0$ components [6] and combined use of two-phase and three-phase symmetrical components method [7]. The phase parameter description for the six-phase line in order to derive

fault current and voltage expressions was also employed in some studies [3,4,8].

The total number of faults increases with the increasing phase order making the fault analysis of multi-phase system a difficult task [11]. Further solving each fault separately is quite cumbersome. There have been attempts to unify the procedure so that the same equation is employed to analyse system faults irrespective of fault type, for six-phase system [9] and twelve-phase system [11] neglecting the fault impedance/admittance. This paper is a step forward in this direction to generalise the three-phase technique [12] for a multi-phase system taking into account the fault impedance/admittance. For this purpose a general fault impedance/admittance matrix is derived for an N-phase system. A mere substitution of relevant values for any fault (with fault impedance) type can be simulated. However, if the fault impedances are neglected, the procedure yields a single equation for computing fault currents involving phases, phases to ground and also their combinations. The simplicity and ease with which the equations can be used to carry out fault analysis on multi-phase transmission systems is amply demonstrated by several illustrative calculations. Further the utility of the formulation to obtain the most and least severe fault in a six-phase transmission and a comparative view of performance of various multi-phase system during fault condition is shown in this paper.

FORMULATION AND ANALYSIS OF FAULT PROBLEM

A twelve-phase transmission system can be represented as in Fig.1 for the purpose of simulation of fault condition. Assuming an unloaded twelve-phase system, the performance of the system during fault can be written as:

$$V_{ph}^{12} = E_{ph}^{12} - I_f^{12} Z_{ph}^{12} \tag{1}$$

$$I_f^{12} = Y_f^{12} (U + Z_{ph}^{12} Y_f^{12})^{-1} E_{ph}^{12} \tag{2}$$

$$= (Z_f^{12} + Z_{ph}^{12})^{-1} E_{ph}^{12} \tag{3}$$

where Z_{ph}^{12} is the twelve-phase impedance matrix with self impedance $Z_{ii} = Z_i$ and mutual impedance $Z_{ij} = Z_m$; $i = j; i, j = 1, 2, \dots, 12$.

Z_f^{12} / Y_f^{12} is the fault impedance/admittance matrix used to describe and simulate a desired type of fault;

U is the unit matrix;

E_{ph}^{12} is the known voltage vector prior to the fault

$$= [E_a \ E_b \ \dots \ E_l]^t$$

$$= E [C^{12} \ C^{11} \ \dots \ C]^t;$$

$$V_{ph}^{12} = [V_a \ V_b \ \dots \ V_l]^t;$$

C is the twelve-phase operator = $\text{Exp}(j2\pi/12)$.

Derivation of General Fault Impedance/Admittance Matrix

All shunt faults can be simulated by employing an appropriate fault impedance or admittance matrix. The procedure for the formulation of such matrices are illustrated below.

Considering a twelve-phase system subjected to a twelve-phase to ground fault as shown in Fig.2. Taking the ground as reference, the phase voltage to ground fault at the fault point are given by:

$$\begin{aligned} V_{fa} &= I_{fa}(Z_{fa} + Z_g) + (I_{fb} + I_{fc} + \dots + I_{fl}) Z_g; \\ V_{fb} &= I_{fb}(Z_{fb} + Z_g) + (I_{fa} + I_{fc} + \dots + I_{fl}) Z_g; \\ &\vdots \\ V_{fl} &= I_{fl}(Z_{fl} + Z_g) + (I_{fa} + I_{fb} + \dots + I_{fk}) Z_g; \end{aligned} \quad (4)$$

Eqns.(4) can be written in the following compact form:

$$V_f^N = Z_f^N I_f^N \quad (5)$$

where Z_f^N is the N-phase fault impedance matrix (N=12) with $Z_{ii} = Z_{fi} + Z_g$ and $Z_{ij} = Z_g$; $i, j = a, b, \dots, l$ & $i = j$.

Limitations:

A variety of shunt faults can't be simulated by this fault impedance matrix. Therefore, the fault impedance matrix is not useful and the need exists for a generalised formulation of fault admittance matrix.

The node equation for the circuit of Fig.2 can be written as:

$$\begin{bmatrix} I_{fa} \\ I_{fb} \\ \vdots \\ I_{fl} \\ \hline I_n \end{bmatrix} = \begin{bmatrix} Y_{fa} & & & & & \\ & Y_{fb} & & & & \\ & & \ddots & & & \\ & & & Y_{fl} & & \\ \hline & & & & & Y_g \end{bmatrix} \begin{bmatrix} V_{fa} \\ V_{fb} \\ \vdots \\ V_{fl} \\ \hline V_n \end{bmatrix} \quad (6)$$

By eliminating node n from Eq.(6), the fault admittance matrix for the 12-phase to ground can be found as:

$$Y_f^N = [A] / (Y_g + \sum_{k=1, k \neq i}^N Y_{fk}) \quad (7)$$

where the elements of the A-matrix are given by:

$$\begin{aligned} a_{ii} &= Y_{fi} (Y_g + \sum_{k=i, k=1}^N Y_{fk}) \\ a_{ij} &= -Y_{fi} Y_{fj} \quad ; i = j, i, j = 1, 2, \dots, N \end{aligned}$$

(or $i, j = a, b, \dots, l$ respectively for the 12-phase system.)

The above equation can be used to obtain the fault admittance matrix for any type of shunt faults except for bolted ground faults with $Z_{fi} =$

$Z_0 = 0$ and bolted interphase faults for which $Z_{f_{i,j}} = 0$. Bolted phase-to-ground and phase-to-phase faults are dealt with separately in the following.

Derivation of general Expressions for Fault Currents and Voltages

In case when the fault impedance is neglected, a method for evaluating fault currents and voltages for all types of faults is developed in this section. In the development to follow the twelve-phase system is assumed to be balanced, unloaded and fully transposed.

Evaluation of Fault Currents

The fault currents can be obtained by solving Eq.(1) together with the boundary conditions of the fault. The following expression for fault current due to any bolted ground fault has already been developed earlier in paper [11].

$$I_j = E_{\phi} / Z_1 [P^{N+1-j} - (Z_0 - Z_1) / \{nZ_0 + (N-n)Z_1\} (\sum_{i=1}^N P^{N+1-i} F_i)] \quad (8)$$

where F_i is the fault coefficient = 1 for the i^{th} phase involved in the fault and = 0 for the i^{th} phase isolated from the fault;

N is the total number of phases;

n is the number of faulted phase;

Z_0 & Z_1 are zero and positive sequence impedances respectively;

P is the phase operator = $\text{Exp}(j 2\pi/N)$.

The expression for the fault current caused by interphase faults can be obtained in a similar way as described in [11]. The procedure is illustrated for the following three interphase faults:

i- Two-phase fault (a,b)

Boundary conditions $V_a = V_b$; $I_a + I_b = 0$, and $I_c = I_d = \dots = I_i = 0$.

$$\left. \begin{aligned} \text{The fault currents } I_a &= E_{\phi} (C^{12} - C^{11}) / 2(Z_{\phi} - Z_m) \\ I_b &= E_{\phi} (C^{11} - C^{12}) / 2(Z_{\phi} - Z_m) \end{aligned} \right\} \quad (9)$$

ii- Three-phase fault (a,b,c)

Boundary conditions $V_a = V_b = V_c$; $I_a + I_b + I_c = 0$ & $I_d = I_e = \dots = I_i = 0$.

$$\left. \begin{aligned} \text{The fault currents } I_a &= E_{\phi} (2C^{12} - C^{11} - C^{10}) / 3(Z_{\phi} - Z_m) \\ I_b &= E_{\phi} (2C^{11} - C^{12} - C^{10}) / 3(Z_{\phi} - Z_m) \\ I_c &= E_{\phi} (2C^{10} - C^{12} - C^{11}) / 3(Z_{\phi} - Z_m) \end{aligned} \right\} \quad (10)$$

iii- Four-phase fault (a,b,c,d)

Boundary conditions $V_a = V_b = V_c = V_d$; $I_a + I_b + I_c + I_d = 0$ & $I_e = I_f = \dots = I_i = 0$.

$$\left. \begin{aligned} \text{The fault currents } I_a &= E_{\phi} (3C^{12} - C^{11} - C^{10} - C^0) / 4(Z_{\phi} - Z_m) \\ &\vdots \\ I_d &= E_{\phi} (3C^0 - C^{12} - C^{11} - C^{10}) / 4(Z_{\phi} - Z_m) \end{aligned} \right\} \quad (11)$$

The expressions (9-11) are arranged so as to yield the general expres-

sion (12) which gives the fault current resulting from any type of interphase faults on any phase order.

$$I_j = E_a / Z_1 [P^{N+1-j} - (\sum_{l=1}^N P^{N+1-l} F_l) / n] \quad (12)$$

Eqns (8&12) can be combined to get the following general fault current expression:

$$I_j = E_a / Z_1 \left\{ P^{N+1-j} - [(1-\alpha)(Z_0 - Z_1) / \{nZ_0 + (N-n)Z_1\} + \alpha/n] (\sum_{l=1}^N P^{N+1-l} F_l) \right\} \quad (13)$$

where α is a fault type coefficient taken equal to 1 for the interphase faults and 0 for ground faults.

Evaluation of Post-Fault Voltages

The post-fault voltages for the three faults discussed earlier are given by:

$$\begin{aligned} \text{i- (a,b) fault} \quad & \left. \begin{aligned} V_a = V_b = E_a (C^{12} - C^{11}) / 2 \\ V_c = C^{10} E_a \\ \vdots \\ V_l = C E_a \end{aligned} \right\} \quad (14) \end{aligned}$$

$$\begin{aligned} \text{ii- (a,b,c) fault} \quad & \left. \begin{aligned} V_a = V_b = V_c = E_a (C^{12} - C^{11} - C^{10}) / 3 \\ V_d = C^0 E_a \\ \vdots \\ V_l = C E_a \end{aligned} \right\} \quad (15) \end{aligned}$$

$$\begin{aligned} \text{iii- (a,b,c,d) fault} \quad & \left. \begin{aligned} V_a = V_b = V_c = V_d = E_a (C^{12} - C^{11} - C^{10} - C^0) / 4 \\ V_e = C^0 E_a \\ \vdots \\ V_l = C E_a \end{aligned} \right\} \quad (16) \end{aligned}$$

The Eqns. (14-16) are suitably arranged so as to give the following general formula:

$$V_j = E_a [(1-F_j) P^{N+1-j} + F_j (\sum_{l=1}^N P^{N+1-l} F_l) / n] \quad (17)$$

which gives the post-fault voltage of faulty phases for any type of interphase fault. The post-fault voltages of sound phases for any bolted ground fault are given by [11]:

$$V_j = E_a [P^{N+1-j} - (Z_0 - Z_1) / \{nZ_0 + (N-n)Z_1\} (\sum_{l=1}^N P^{N+1-l} F_l)] \quad (18)$$

Eqns. (17&18) may be also combined in one equation as follows:

$$V_j = E_a \left\{ (1-F_j) P^{N+1-j} - [(1-\alpha)(1-F_j)(Z_0 - Z_1) / \{nZ_0 + (N-n)Z_1\} - \alpha F_j / n] * (\sum_{l=1}^N P^{N+1-l} F_l) \right\} \quad (19)$$

Eq. (13) and Eq. (19) are used to compute the fault current and the sound phase voltage for all the possible types of bolted ground and interphase faults.

ILLUSTRATIVE CALCULATIONS

The expressions developed in this paper are applied to evaluate the performance of multi-phase systems under fault conditions employing the conductor configurations and line geometries shown in Fig. 3. The following line parameters and fault specifications are considered:

X_0 and X_1 (in Ω /mile) are (3- ϕ) 1.928 & 0.398 ; (6- ϕ) 3.678 & 0.534 and (12- ϕ) 7.149 & 0.566 respectively.

Resistances and shunt admittances of the line are neglected.

Fault location = 200 miles from the sending end.

Fault resistance between any two phases = 2 Ω .

$R_{f1} = 4 \Omega$.

Ground fault resistance $R_g = 106.8 \Omega$.

The results of the fault analysis with and without the fault impedances/admittances for the six-phase line depicted in Fig.3 are presented in table 1. It can be observed from this table that:

- i- The inclusion of fault impedances/admittances in the calculation of the fault currents leads to a decreasing some fault currents and an increasing with some others.
- ii- The (a,b,d,p,n) fault is the most severe fault with a maximum current of 5.419 kA in phase d.
- iii- The (a-n) fault is the least severe fault with a minimum current of 1.945 kA in phase a.
- iv- For all other results, the current magnitudes lie between 2.161 kA and 5.407 kA. Thus for the line under consideration the range of the fault currents varies from 1.945 kA to 5.914 kA.

Table 2 shows the obtained values of the fault currents and voltages for single-phase to ground, all phases to ground and two-phase faults on three-phase, six-phase and twelve-phase lines (Fig.3). From the results, it can be seen that multi-phase systems are found to possess lower values of fault currents than three-phase system. This may require circuit breakers of lower ratings per phase to be used with multi-phase system.

Table 1

Fault currents for all the significant faults in six-phase system

Fault Type	Phase Current(kA)					
	With fault admittance included * Without fault admittance					
	a	b	c	d	e	f
a,n	1.945 -62.5 * 2.183 -90.0					
a,b,n	2.858	1.83				

	-45.8 * 2.506 -60.3	-122.4 2.506 -179.7			
a, b	2.161 -27.900 * 2.163 -30.000	2.161 152.100 2.163 150.000			
a, c, n	4.097 -65.000 * 3.817 -71.000	0.0 0.0 0.0 0.0	3.459 130.600 3.817 131.000		
a, c	3.744 -57.900 * 3.746 -60.900	0.0 0.0 0.0 0.0	3.744 122.100 3.746 120.000		
a, d, n	4.323 -87.000 * 4.326 -90.000	0.0 0.0 0.0 0.0	0.0 0.0 0.0 0.0	4.323 93.000 4.326 90.000	
a, d	4.323 -87.900 * 4.326 -90.000	0.0 0.0 0.0 0.0	0.0 0.0 0.0 0.0	4.323 93.000 4.326 90.000	
a, b, c, n	4.087 -54.400 * 3.746 -60.200	1.944 -137.400 2.173 -150.000	3.417 118.400 3.746 120.200		
a, b, c	3.940 -48.400 * 3.815 -49.100	1.449 -143.600 1.442 -150.000	3.682 109.900 3.815 109.900		
a, b, d, n	4.027 -71.600 * 3.901 -76.1	3.123 -144.800 3.250 -150.000	0.0 0.0 0.0 0.0	4.910 79.900 4.953 79.200	
a, b, d	3.876 -69.600 * 3.815 -70.900	2.882 -147.600 2.884 -150.000	0.0 0.0 0.0 0.0	5.144 76.700 5.199 76.1	
a, c, e, n	4.323 -87.900 * 4.325 -90.000	0.0 0.0 0.0 0.0	4.323 152.100 4.325 150.000	0.0 0.0 0.0 0.0	4.323 32.100 4.325 30.000
a, c, e	4.321	0.0	4.321	0.0	4.321

E.58 I.I.I. Mansy

	-88.900	0.0	151.100	0.0	31.500	
	* 4.326	0.0	4.326	0.0	4.326	
	-90.000	0.0	150.000	0.0	30.000	
a, b, c, d, n	4.785	3.150	2.899	4.456		
	-67.900	-130.000	138.900	70.700		
	* 4.576	3.124	3.124	4.576		
	-71.000	-136.200	136.200	71.000		
a, b, c, d	4.723	2.867	2.867	4.723		
	-64.400	-128.800	133.000	68.700		
	* 4.714	2.861	2.861	4.714		
	-66.600	-130.900	130.900	66.600		
a, b, d, e, n	3.466	3.466	0.0	3.466	3.466	
	-87.300	-147.300	0.0	92.700	32.700	
	* 4.325	4.325	0.0	4.325	4.325	
	-90.000	-150.000	0.0	90.000	30.000	
a, b, d, e	4.342	4.342	0.0	4.342	4.342	
	-86.300	-145.200	0.0	93.700	34.800	
	* 4.326	4.326	0.0	4.326	4.326	
	-90.000	-150.000	0.0	90.000	30.000	
a, b, d, f, n	3.232	3.358	0.0	5.419	0.0	3.831
	-90.300	-147.800	0.0	93.600	0.0	-15.000
	* 3.464	3.996	0.0	5.188	0.0	3.996
	-90.000	-160.800	0.0	90.000	0.0	-19.200
a, b, d, f	3.251	3.907	0.0	5.418	0.0	3.906
	-87.900	-161.800	0.0	92.100	0.0	-14.000
	* 3.244	3.899	0.0	5.407	0.0	3.899
	-90.000	-163.900	0.0	90.000	0.0	-16.100
a, b, c, d, e, n	4.810	4.057	3.551	3.929	4.703	
	-80.300	-137.900	153.200	82.900	23.600	
	* 4.727	4.015	3.607	4.015	4.727	
	-82.400	-141.100	150.000	81.100	22.400	
a, b, c, d, e	4.815	3.963	3.458	3.962	4.815	
	-78.900	-136.900	152.200	81.300	23.200	
	* 4.817	3.965	3.461	3.965	4.817	
	-81.100	-139.100	150.000	79.100	21.100	
a, b, c, d, e, f, n	4.323	4.323	4.323	4.323	4.323	4.323
	-87.900	-147.900	152.100	92.100	32.100	-27.900
	* 4.326	4.326	4.326	4.326	4.326	4.326
	-90.000	-150.000	150.000	90.000	30.000	-30.000
a, b, c, d, e, f	4.323	4.323	4.323	4.323	4.323	4.323
	-87.900	-147.900	152.100	92.100	32.100	-27.900
	* 4.326	4.326	4.326	4.326	4.326	4.326
	-90.000	-150.000	150.000	90.000	30.000	-30.000

Table 2
Comparative value of phase fault currents and voltages for
three-phase, six-phase and twelve-phase system

Fault Type	Three-phase		Six-phase		Twelve-phase	
	Fault current kA	Fault Voltage kV	Fault current kA	Fault Voltage kV	Fault current kA	Fault Voltage kV
Single-phase to ground fault	2.166	240.702	1.945	213.689	1.852	205.725
	* 2.544	* 0.0	* 2.183	* 0.0	* 2.073	* 0.0
All-phases to ground fault	5.802	23.212	4.323	17.291	4.068	16.273
	* 5.804	* 0.0	* 4.326	* 0.0	* 4.079	* 0.0
Two-phase fault (a,b)	5.022	251.096	2.161	408.743	1.045	450.564
	* 5.026	* 231.00	* 2.163	* 400.101	* 1.051	* 446.252

* Values without fault impedances.

CONCLUSIONS

This paper is concerned with the generalised analysis of shunt faults in multi-phase system with the inclusion of fault impedance/admittance. For this analysis a general expression of fault impedance/admittance matrix is presented. These fault impedance/admittance matrices can be generated for any phase order and thus any type of shunt fault can be simulated.

Two general equations have also been developed to determine the fault currents and post-fault voltages for all types of faults having negligible fault impedances.

The validity of the expressions developed and their applicability for any phase order have been demonstrated through the illustrative calculations. These expressions give good agreements with the previously available results which are summarised as follows:

- i- The four phases and the single-phase to ground faults are the most and least severe faults respectively in a six-phase system.
- ii- The fault levels of multi-phase systems are less than those of 3-phase system and this may allow circuit breakers with lower rating per phase to be used.

REFERENCES

- 1-J.R. Stewart and D.D. Wilson, "High Phase Order Transmission- a Feasibility Analysis.", IEEE Trans. PAS-97, 1978, pp.2300-2317.

- 2- N.B. Bhatt, S.S. Venkata, W.C. Guyker and W.H. Booth, "Six-Phase (Multi-phase) Power Transmission System: Fault Analysis.", IEEE Trans., PAS-96, 1977, pp. 758-764.
- 3- S.P. Nanda, S.N. Tiwari and L.P. Singh, "Fault analysis of Six-Phase Systems.", Electric Power System Res., 4, 1981, pp. 201-211.
- 4- S.N. Tiwari and L.P. Singh, "Six-Phase (Multi-Phase) Power System: Some Aspects of Modelling and Fault Analysis.", Elect. Power Sys. Res., 6, 1983, pp. 193-202.
- 5- J.L. Willems, "Fault Analysis and Components Schemes for Polyphase Systems.", Int. J. Electr. Power Energ. Syst., 2, 1980, pp. 43-48.
- 6- S.H. Peeran, M.A. Neema and H.I. Zynal, "Six-Phase Transmission Systems: Generalized Alpha-Zero Components and Fault Analysis.", IEEE PES Summer Meeting, Vancouver, 1979, Paper No. A79, pp. 536-544.
- 7- Y. Onogi and Y. Okumoto, "A method of Fault Analysis and Suppression of Fault Current in Six-Phase Power Transmission Systems.", Electr. Eng. Jpn., 99, 1979, pp. 50-58.
- 8- S.S. Venkata, W.C. Guyker and others, "138 kV, Six-Phase Transmission Systems: Fault Analysis.", IEEE Trans., PAS, 101, 1987, pp. 1203-1218.
- 9- R.D. Sharma and B.K. Bhatt, "Generalised Treatment of Ground Faults in Six-Phase Power System.", Journal of Institution of Engineers, Vol. 68, pt EL 1, Aug., 1987, pp. 12-29.
- 10- Uma Pal and L.P. Singh, "Feasibility and Fault Analysis of Multi-Phase (Twelve-Phase) System.", Journal of Institution of Engineers, Vol. 65, pt. EL4, Feb., 1985, pp. 138-146.
- 11- A.S. Bin Saroor, S.N. Tiwari and C.P. Gupta, "An Analysis of Ground Faults in Multi-Phase Transmission Systems.", Fifth National Power System Conference, Bangalore, Sep., 1988, CPRI, pp. 173-177.
- 12- G.W. Stagg and E.H. El-Abiad, "Computer Methods in Power System Analysis.", McGraw Hill, New York, 1968.

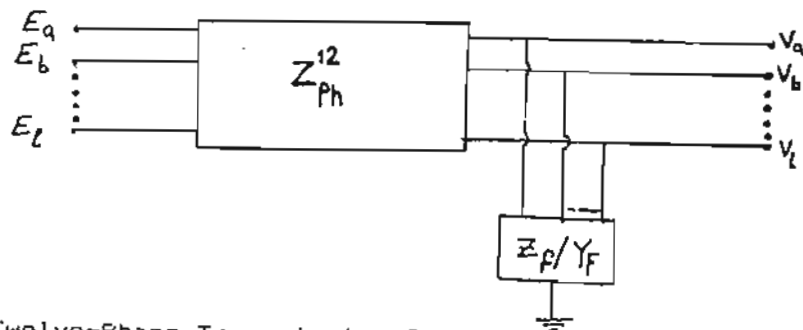

Fig.1 Twelve-Phase Transmission System for Simulating Shunt Faults.

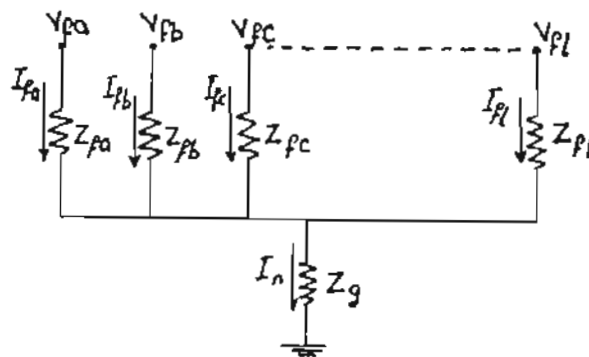

Fig.2 Schematic Representation of 12-Phase to Ground Fault on Twelve-Phase Transmission Line.

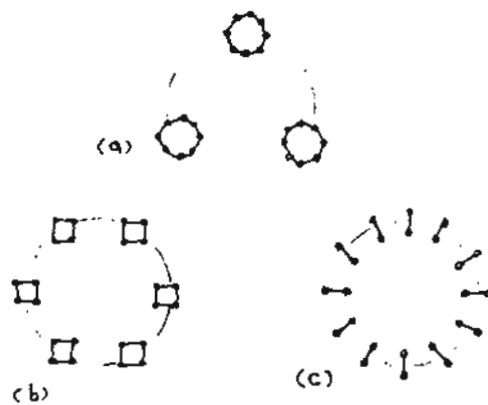

Fig.3 Conductor Configurations for 462 kV Phase-Ground Line (24/ 1.762 in. Conductors, 15 ft. Diameter Circle, 18 in. Bundle Distance, 50 ft. Min. Ground Clearance);
 a) 3-Phase Line; b) 6-Phase Line & c) 12-Phase Line.