

**An Electronic Device for The
measurement of an earth-loop Impedance**

Ahmed Abdul-Maguid Hassan , Ph.D. and Adnan Allaway
Ftaiet , M.Sc.

ABSTRACT:

The measurement of an earth-loop impedance using high testing current of short duration has been broadly investigated. Thus, an experimental instrumentation model has been developed, built and tested. Obtained results have been compiled with other simulated measurements using different measuring techniques. Comparison of the two sets of results showed high accuracy of the developed electronic measuring device in addition to its compactness and reliability.

1. Introduction:

It is well known that, the effectiveness of the earthing system of an electrical installation must be checked periodically to ensure the presence of a low-impedance path for a fault current. The accurate measurement is of prime importance due to the low-impedance value in this case. Therefore, efforts have been directed towards the development of a simple, accurate and portable measuring device, by which the earth-loop impedance can periodically be instrumented.

Techniques of measuring grounding impedance are mostly based upon circulating a test current into the grounding system as schematically shown in Fig. (1). Measurement of the circulated current and the resulting voltage change produced on the grounding system yields the necessary information to calculate the required earth-loop impedance (Z_g) of Fig. (1). The accuracy of the measurement depends on the state variables of the system. To minimize measuring errors, the test current should be high enough to simulate the fault currents and should have a limited-time duration to avoid interference with protective devices. The limited-time duration of the test current should be selected so as to reduce the error due to electrical transients resulting from the measuring process itself and transients that might be present during the measurement.

Accordingly, an electronic measuring device has been developed in view of all mentioned requirements.

2. Description of the developed instrument:

Fig. (2) shows a schematic diagram of the developed measuring device. It consists of three main parts, namely: simulated fault branch, control circuit and the measuring unit.

The simulated fault branch consists of a triac in series with a resistive load. The triac is used as a controlled switch which conducts for two cycles

of the main supply when the gate signal is received from the control circuit.

The control circuit is required to control the timing of the switching operation of the instrument. Three different timing pulses are required as shown in Fig. (3). The different functions of the pulses shown in Fig. (3) are

- a) switching on the thyristorised switch S_1 to charge the capacitor C_1 to the no-load peak voltage V_1 .
- b) switching on the thyristorised switch (T_s).
- c) switching on the thyristorised switch S_2 to charge the capacitor C_2 to the short circuit voltage V_2 .

Fig. (4) shows the circuit diagram of the control circuit of the instrument. The output of the step down transformer (220/6V) is applied to a schmit trigger circuit whose output pulses are fed to the input of a 4-bit binary counter. The required Count sequence and consequently the measuring process are initialized by the push button switch pbs. Measuring time duration is controlled by the one-shot monostable multi-vibrator. The outputs of the counter A, B, C, and D are shown in Fig (5) which indicate the ioperational sequence of the control circuit. The counter outputs are connected to the inputs of the decoder. The output (0) of the decoder is fed to thyristorised switch S_1 through a NAND gate so that S_1 is turend on. The decoder outputs 1 and 2 are gated together and fed to the controlled switch (T_s) so that it will conduct. When the output 2 (see fig.5) is fed to thyristorised switch S_2 , the latter is turned on also. The NAND gates outputs are fed to the triac and thyristor-gate circuits through a power boosting switching transistor which should provide the gate current required for the triac and thyristor's triggerin.

The measureing unit of the experimental set up consists of two thyristors S_1 and S_2 , push-button switches S_3 and S_4 , resistances R_1 to R_4 and capacitors C_1 and C_2 . The charging time of capacitors C_1 and C_2 is schosen to be 1 m sec secwhile the discharge period of the capacitors through the voltmeter should be very long. Howeverthe discharge time of capacitors C_1 and C_2 through reset resistances R_3 and R_4 respectively is chosen to be 1 m sec also. Fig. (6) shows the operational sequence of the measurement circuit.

3. Conclusion

An electronic device for the measurement of earth-loop impedance has been developed, tested and put into working order. The developed device meets the objectives of the periodic instrumentation of the earth-loop impedance. High accuracy range (97.5 - 99.98 %) has been obtained by minimizing effect of transients through the controle of measurement timing. The measured earth loop resistances were in the range of (0.1 - 1) ohm. The developed device is reliable and compact.

REFERENCES

- (1) F.Clish and S.W.Eckett, "Electrical Earth Testing and Monitoring", IEE Conference Publ. No.82, London, 1972, pp.66-72.
- (2) A.T.Baggolt, "Measurement of Earth Fault Impedance in M.V.Supply System", IEE Conference Publ. No.82, London, 1972, pp.162-175.
- (3) P.H. Reynolds, A.H.Silcocks, D.S.Ironside, J.B.Williams, "A new instrument for measuring Ground Impedances" A 79 080-3 IEEE, pp.1-4.
- (4) R.Kosztaluk, M.Lobada, D.Mukhedkar, "Experimental Study of Transient Ground Impedance". IEEE Trans., Vol.PAS 100, No.11, November 1981, pp.4653-4660.

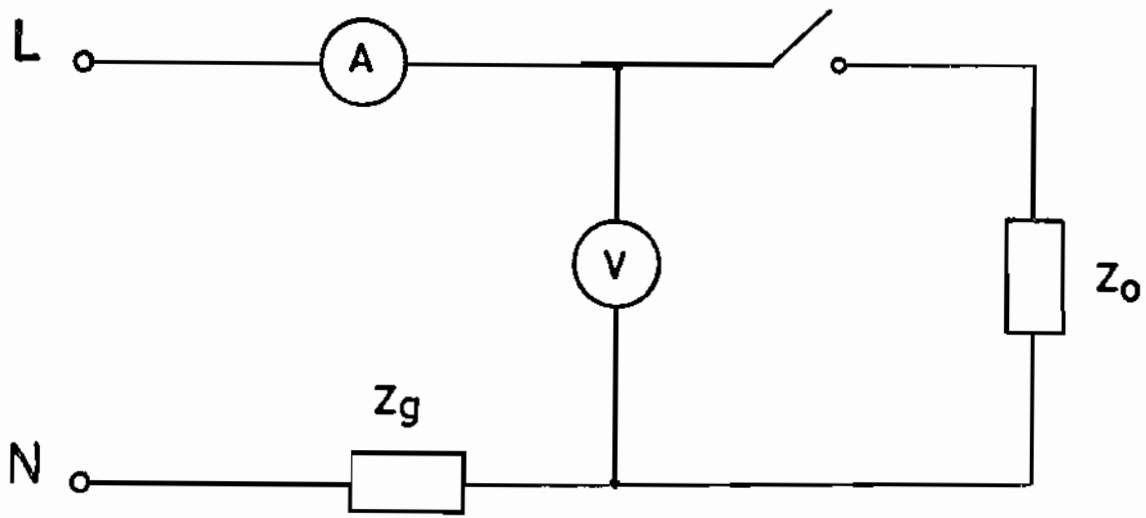

Fig. (1) : Voltmeter - ammeter arrangement for measuring earth - loop impedance .

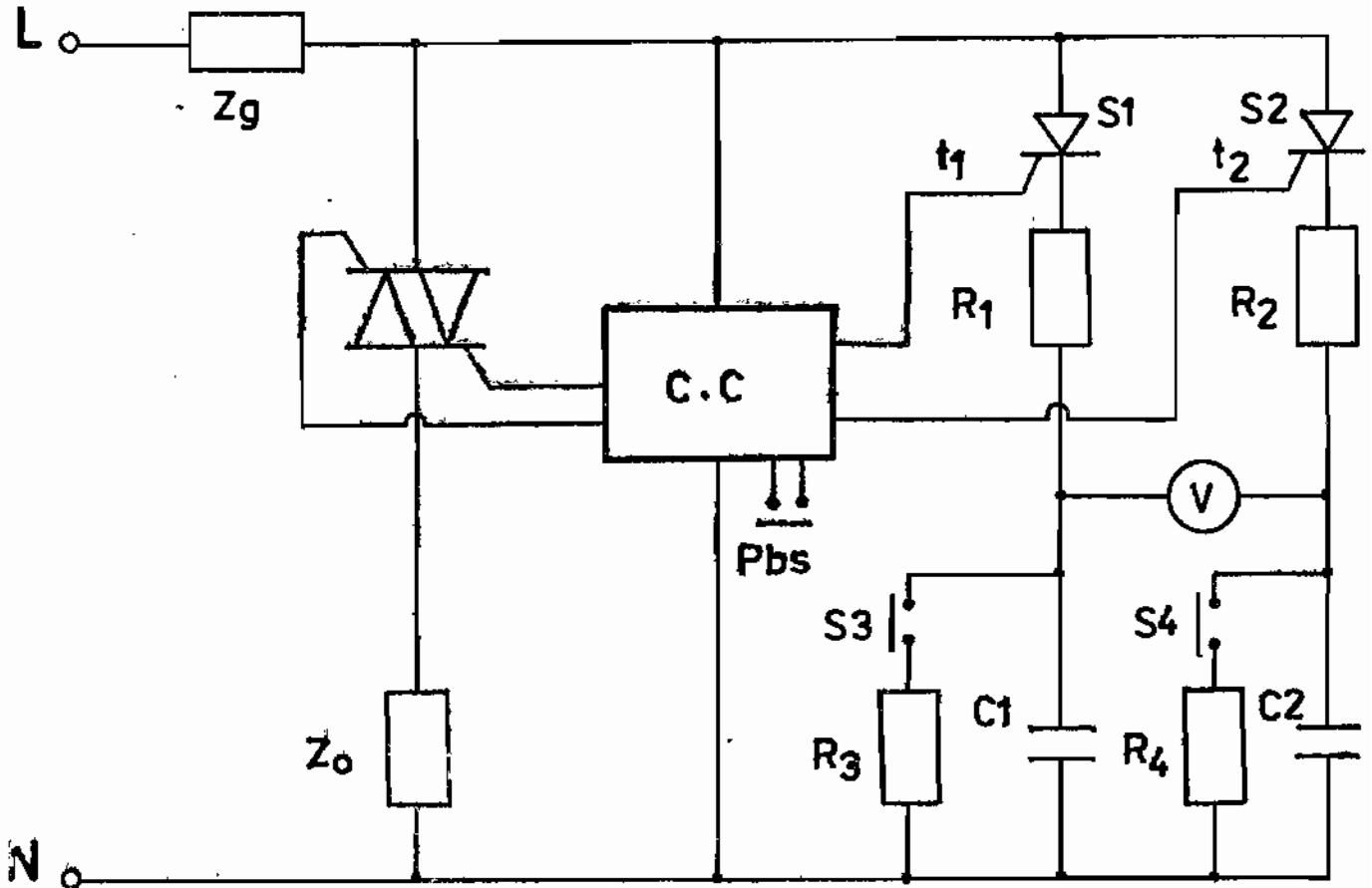

Fig.(2) : Simple circuit for measuring earth - loop impedance .

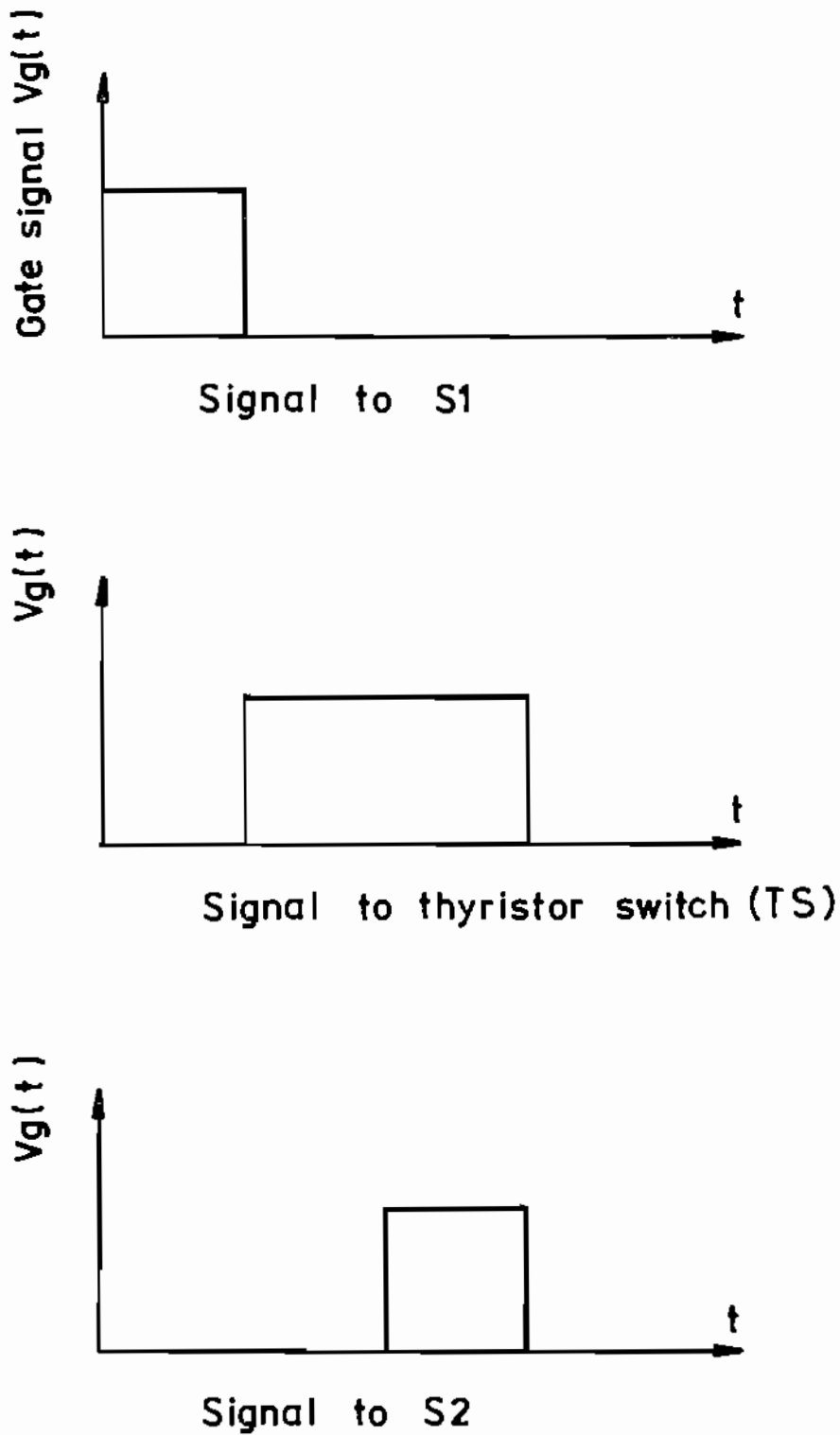

Fig. (3) : Control signal of the instrument.

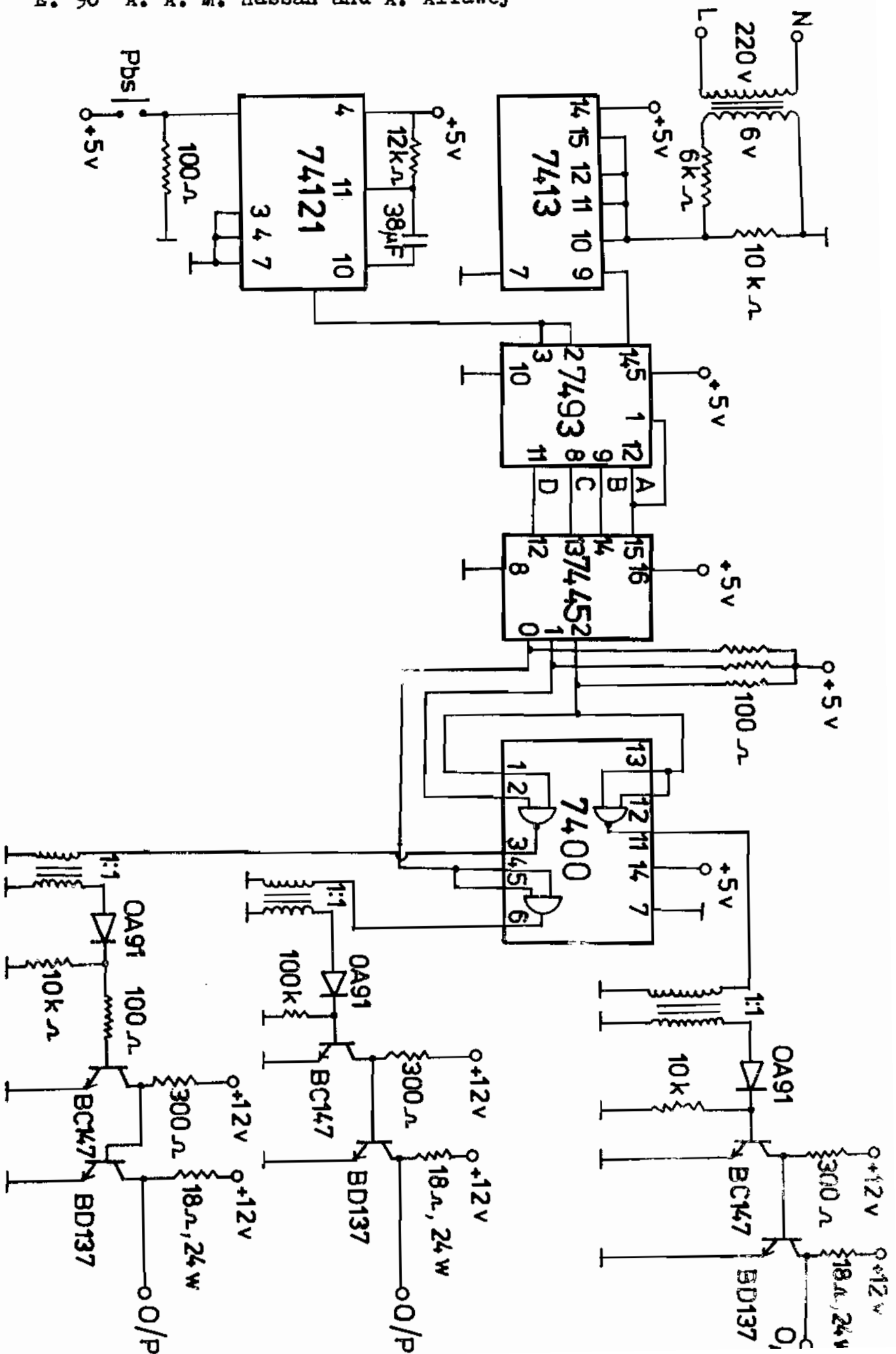

Fig. (4) : Circuit diagram of the control circuit.

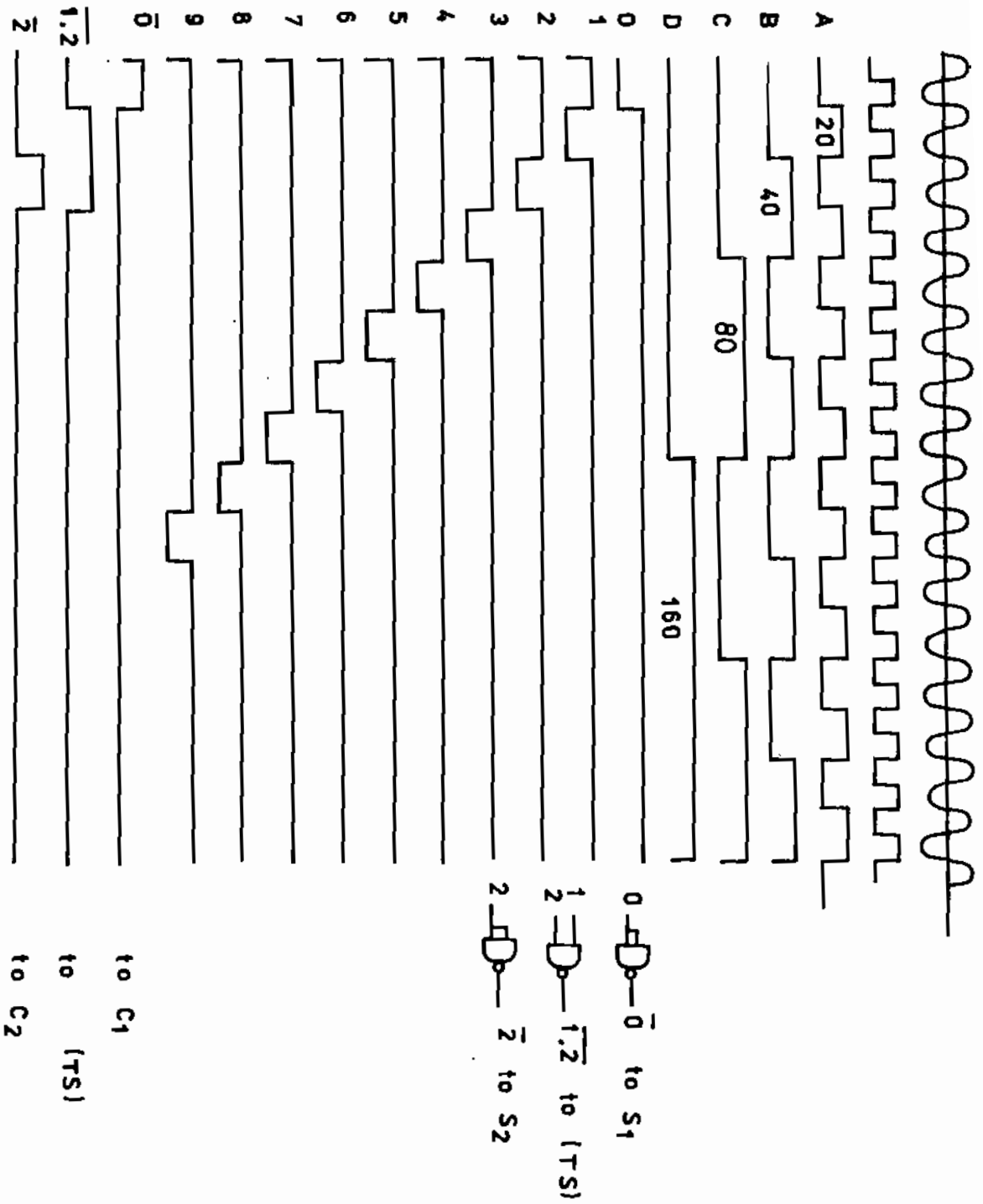

Fig. (5) : Control circuit operational sequence .

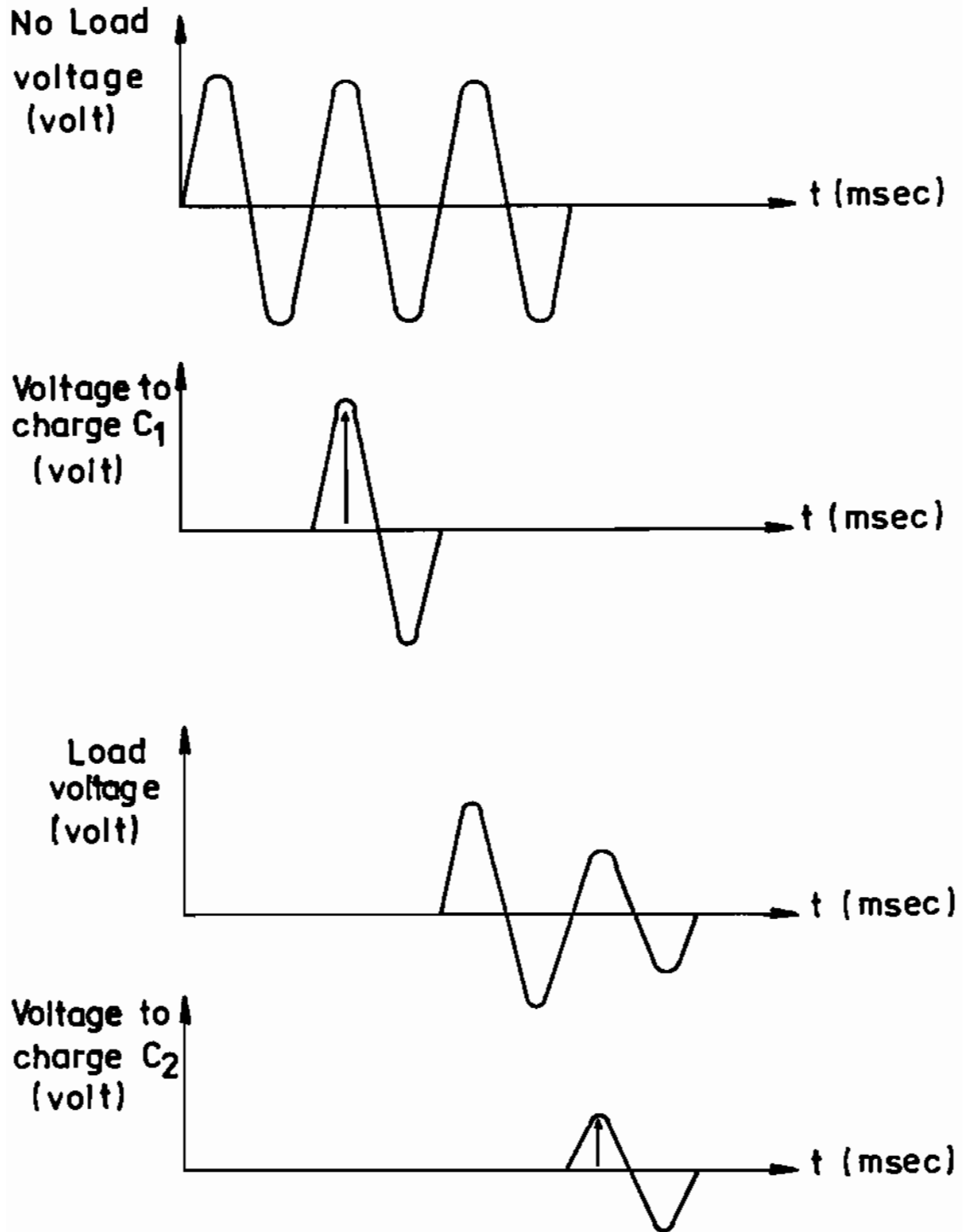

Fig.(6) : Operational sequence of measurement circuit.